

SEVENTH CIRCLE AUDIO



B16-500 Compressor Rev 1

Designed around the THAT 4305 dynamics processor IC, the B16 is a fairly easy to build and use compressor that is useful in a wide variety of applications. The low distortion VCA, Burr-Brown op-amps, and state of the art line driver and receiver ICs combine to form a transparent circuit that keeps levels under control while adding a minimal sonic imprint. An optional transformer allows for a true floating output and some transformer color, if desired. Attack and release timing is generated by a program dependent non-linear capacitor circuit that eliminates the need for separate attack and release controls.

Who Should Build This Kit?

The B16 is not difficult to build, well, other than the 4305 IC...but it also is not intended for absolute beginners. The soldering on the 4305 IC can be done by SCA for an additional charge! You should have built at least one project on a printed circuit board (PCB) before trying the B16. Sorry, but soldering cables doesn't count. If you've never built an electronic project of any kind, this is probably not the one to start with. To guarantee success make sure you have:

- The ability to make basic voltage and resistance measurements using a digital multi-meter (DMM).
- At least a rudimentary understanding of Ohm's Law and the relationship between voltage, current, and resistance.
- Some experience soldering on printed circuit boards.
- The patience to follow instructions precisely and work carefully.

Essential Tools

Fine tipped 20-30 Watt soldering iron w/ cleaning sponge (Hakko 936 or similar)

Eutectic (63/37) rosin core or "no clean" solder (.025" diameter is usually best)

Good-quality DMM

Small needle nose pliers

Small diagonal cutters

Phillips screwdriver (#1)

Flat jeweler's screwdriver

Highly Recommended Tools

Lead bender (Mouser 5166-801)

Magnifying glass

To adjust makeup gain, you'll need the ability to generate and measure audio test signals between -20dBu and +20dBu. Most DAWs can accomplish this task.

Optional Tools

Panavise with circuit board head (PV-312, PV-300, and PV-315 or PV-366) Oscilloscope
Signal generator

Work Area

Find a clean, flat, stable, well-lit surface on which to work. An anti-static mat is recommended for this project. If you're in a dry, static-prone environment, it's highly recommended. The importance of good lighting can't be overstated. Component markings are tiny, and you'll be deciphering a lot of them.

Soldering Technique

Make sure your iron's tip is tinned properly and keep it clean! The trick to making perfect solder joints is to heat the joint quickly and thoroughly before applying the solder, and a properly tinned and clean tip is essential for this. Apply enough solder to form a "fillet" between the lead and the pad, a little mound of solder that smoothly transitions from the plane of the board up to the lead, **but don't use too much**. The finished joint should be smooth and shiny, not rough or gritty looking.

If you've never soldered a board with plated-through holes, you might be surprised to discover how difficult it can be to remove a component once you've soldered it in place. If you're using solder wick to correct a mistake, be very careful not to overheat the pads, since they will eventually delaminate and "lift". It's often better to sacrifice the component and remove its leads individually, then start over with a new part. If for some reason you need to unsolder a multipin component (like a rotary switch or integrated circuit), remove as much solder as you can with solder wick or a solder sucker, and then use a small heat gun to heat all the leads simultaneously. With care, you can remove the component without damaging the board.

Instruction Conventions

Text in **orange** indicates a step where extra care needs to be taken. Doing it wrong isn't a disaster, but it'll need to be corrected.

Text in **red** indicates a step that **must** be done correctly. Doing it wrong will guarantee improper operation, and probably damage components and/or the circuit board.

Assembly

1. Before you begin, carefully unpack the kit and examine the parts. Check the contents of each small bag against the BOM to make sure all the parts have been included. If you think something's missing, please e-mail the details to sales@seventhcircleaudio.com and we'll ship replacement parts ASAP.
2. Generally, the idea when "stuffing" or "populating" a circuit board by hand is to start with the lowest profile parts, such as the resistors, and work your way up to the taller components. In each step below, insert the components, flip the board onto your work surface component-side down, and carefully solder and trim the leads.

Use a piece of stiff cardboard to hold the parts in place while you flip the board. First, orient the board as shown.

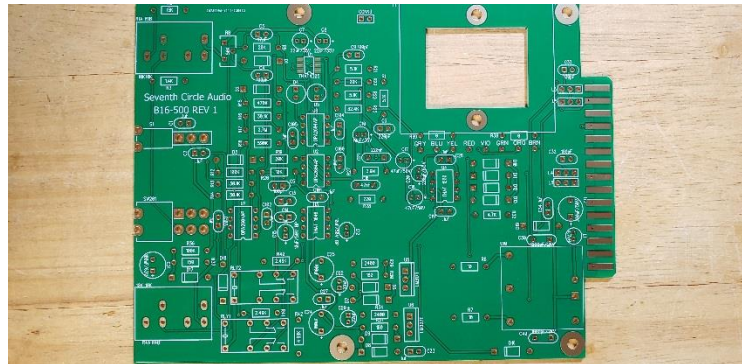

3. Before installing the resistors, prepare the leads using small needle nose pliers or a lead-forming tool as shown here.
Whatever you do, don't bend the leads at the resistor body and force them into the board. This not only results in an ugly job, but it can also damage the parts.

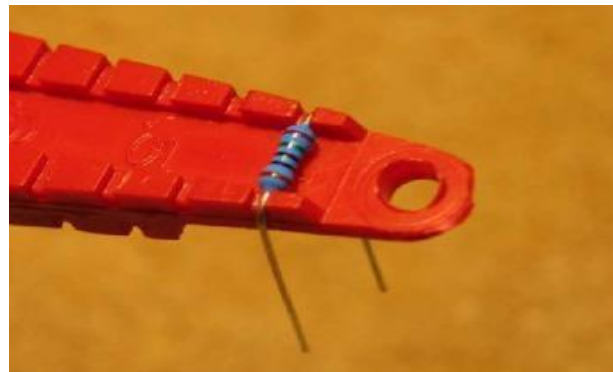

- 4.



Solder U1 taking EXTRA care to not use too much solder and create shorts! Use a microscope, magnifying glass, or cell phone camera, zoomed in, to check your work! IF YOU ARE UNCOMFORTABLE SOLDERING THIS PART, SCA CAN SOLDER IT FOR YOU FOR A SMALL CHARGE!

5. Insert the 1/4-watt resistors. Check the Bill of Materials (BOM) for help in reading the resistor color bands. It's also a good idea to actually measure each resistor with your DMM as you place it on the board, just in case you've read it incorrectly. Don't rely on the photos for component placement. If the resistor value silk-screened on the board doesn't agree with the value on the schematic or parts list, follow the schematic. **You can leave out the two ZERO ohm resistors if you will be installing an output transformer!**

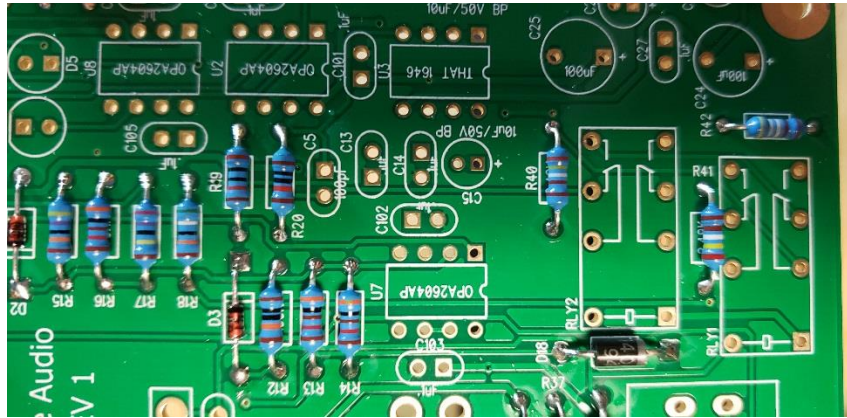

6. Next, add switching diodes D1 through D3. **Diodes are polarized and must be installed the right way around!** The colored band on the diode matches the white band on the silkscreen.

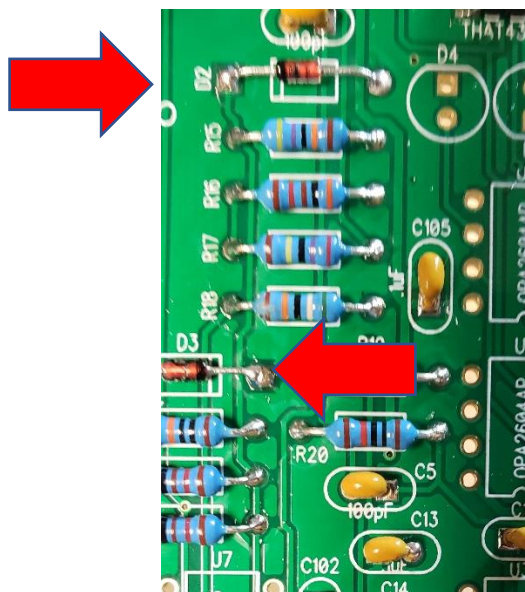

- Next, add the protection diodes D6 through D18, the black ones. **Diodes are polarized and must be installed the right way around!** The colored band on the diode matches the white band on the silkscreen.

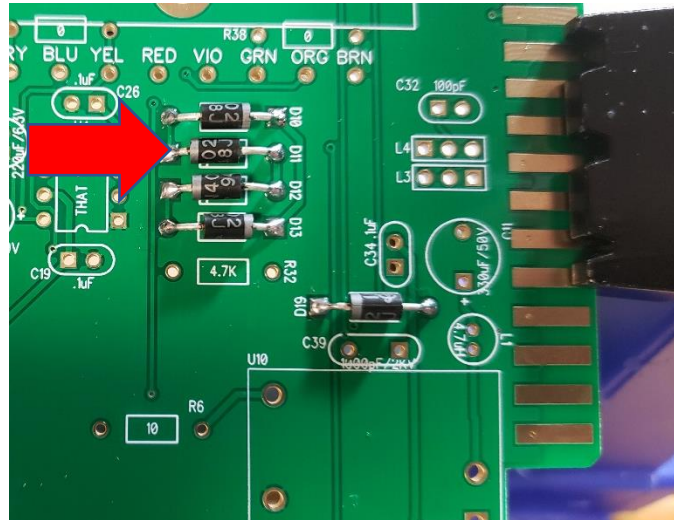

- Install the ceramic, yellow capacitors. These capacitors are not polarized and can be installed in either direction, **but pay close attention to the capacitor markings!** These parts look alike but they are not interchangeable. Putting one in the wrong spot will not prevent the compressor from passing signal, but it can seriously impair its performance!

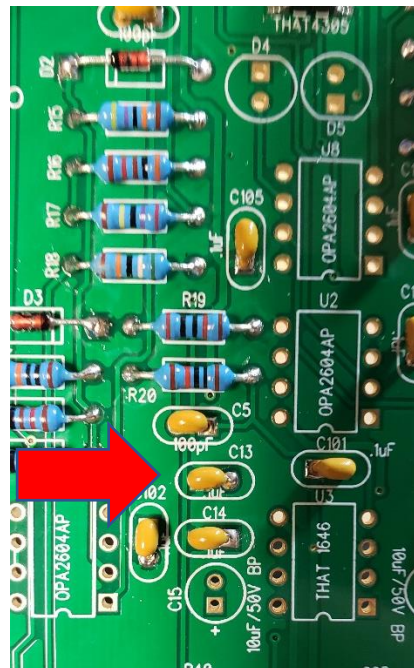

- Install the film capacitors at C16 and C21. These parts are not polarized and can be installed in either direction, **but pay close attention to the capacitor markings!**

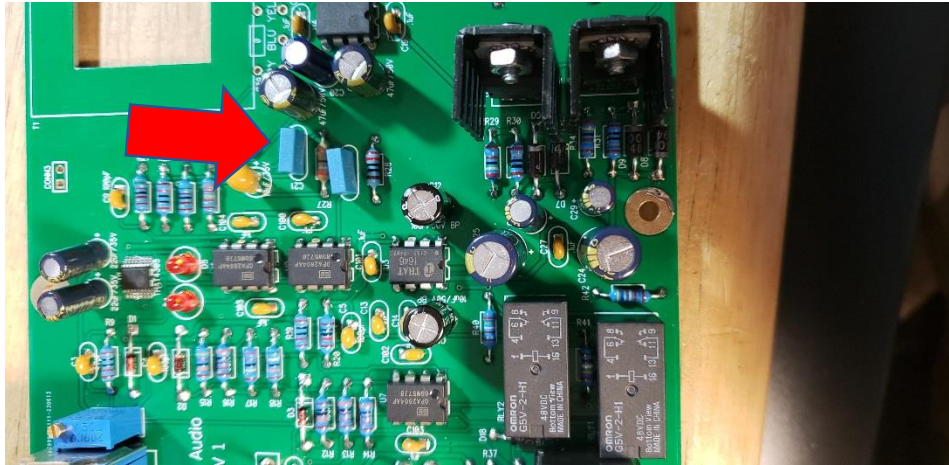

- Install LEDs D4 and D5. **LEDs are polarized and must be installed the right way around!** Install the long lead opposite the flat side of the silkscreen outline.

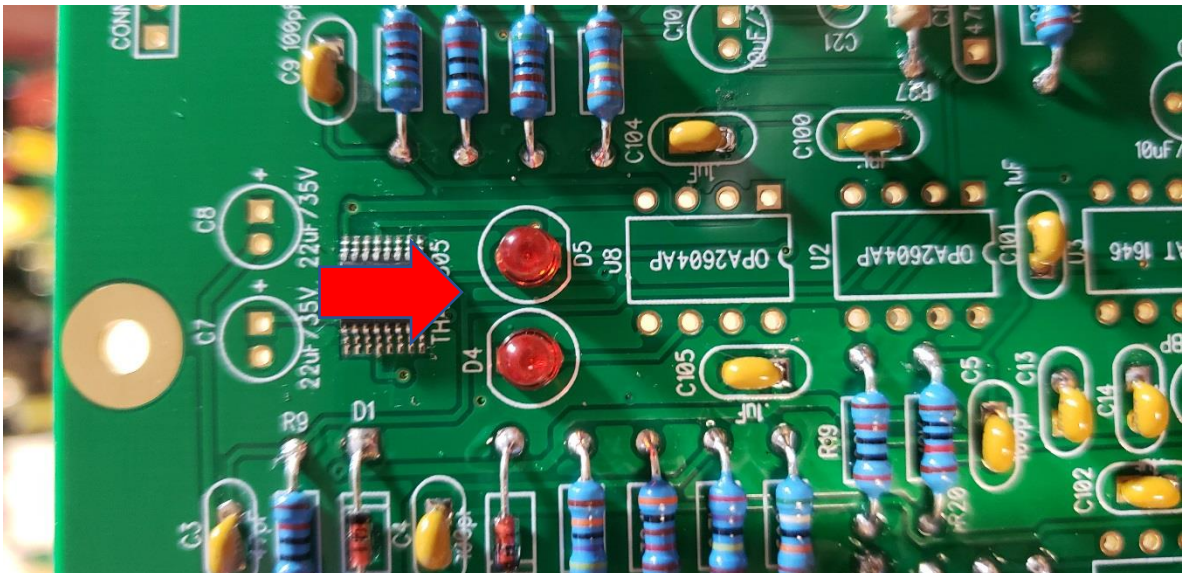

11. Add blue EMI filters L1 through L6. These parts are not polarized and can be installed in either direction.



12. Add tantalum capacitor C10. **Electrolytic capacitors are polarized and must be installed the right way around!** Be absolutely sure to observe the correct polarity when installing these parts. The **positive lead** is marked with a colored stripe. The **positive pad** on the circuit board is marked with a small "+" sign.

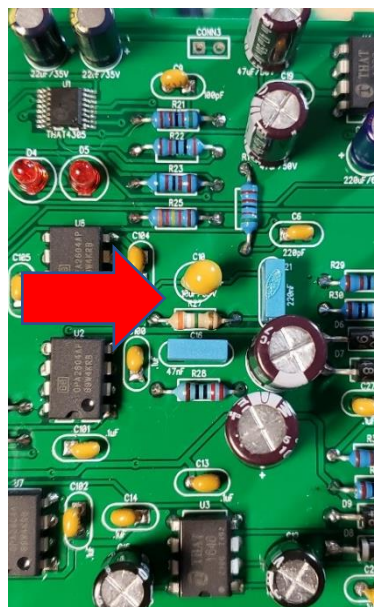

13. Install the aluminum electrolytic capacitors now. **Electrolytic capacitors are polarized and must be installed the right way around!** Be absolutely sure to observe the correct polarity when installing these parts. The **negative leads** of the electrolytic caps are marked with a colored stripe. The **positive pads** on the circuit board are marked with a small "+" sign.

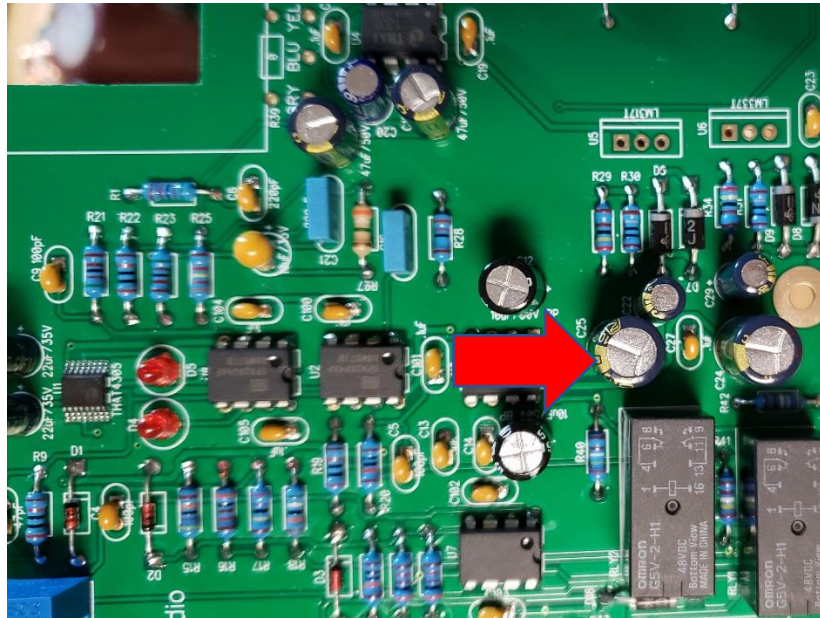

14. Attach trim potentiometer R8.

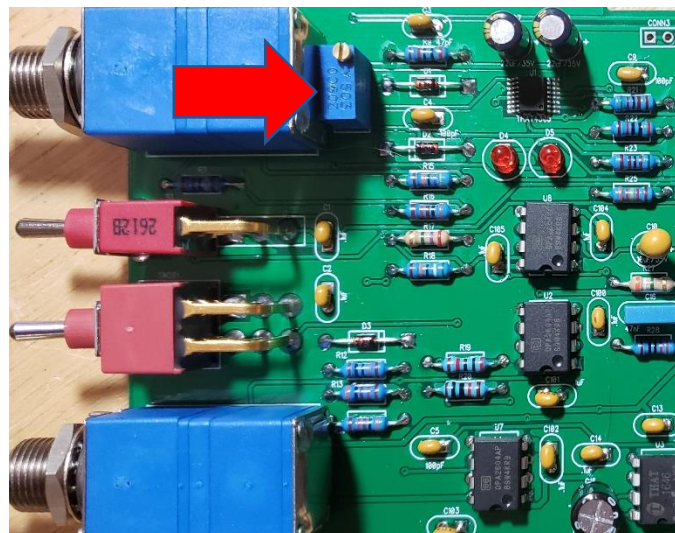

15. Install relays RLY1 and RLY2.

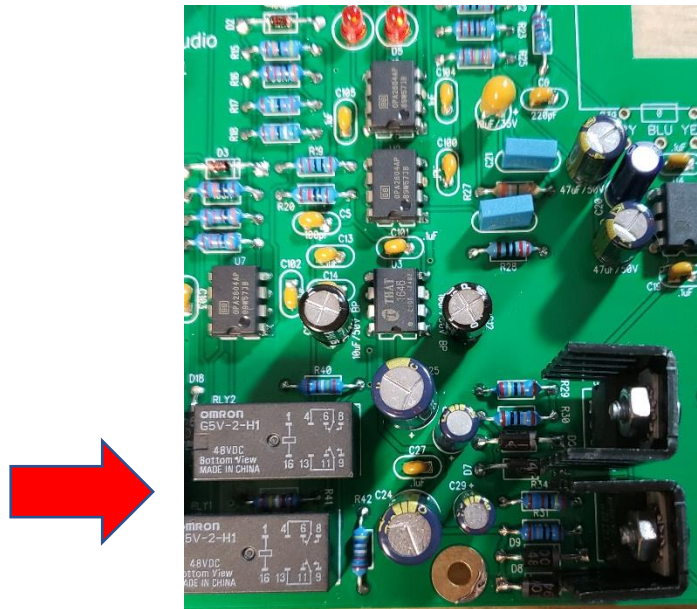

16. Carefully mount the toggle switches SW1 and SW201. Be sure they're seated flat on the board before soldering the leads. You may find it easier to solder the first lead of each switch while the board is component side up.

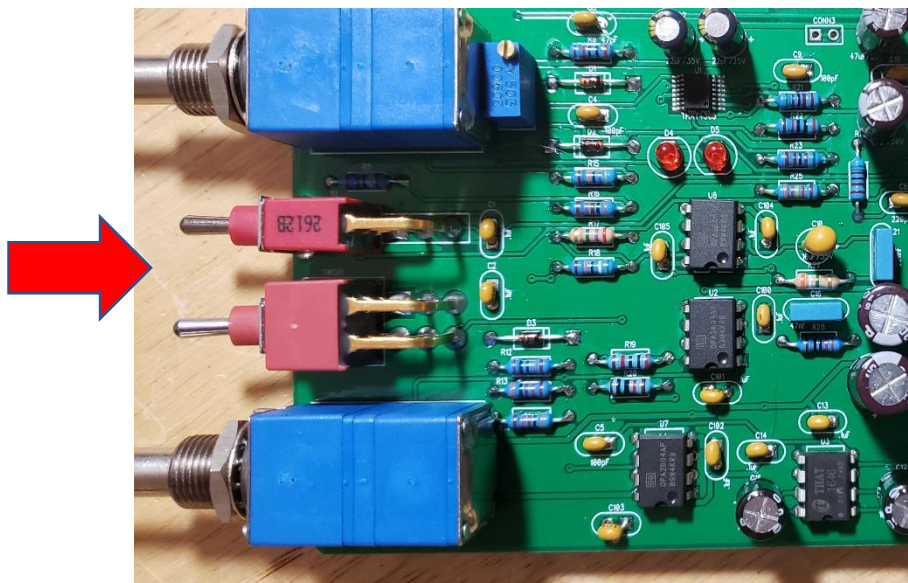

17. Attach panel control potentiometers R1 and R4. Make sure the controls are seated as flat to the board as possible before soldering the leads.

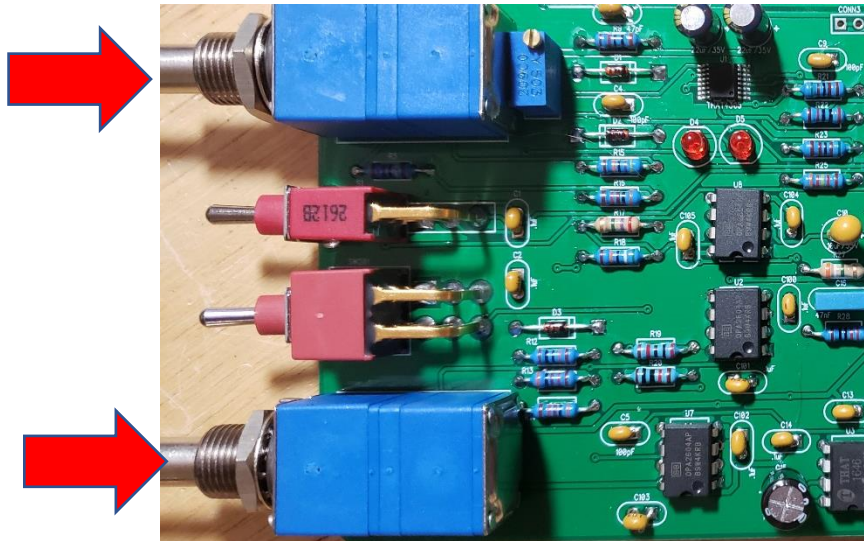

18. Using the hardware supplied, attach heat sinks to U5 and U6 and solder them in place. **Make sure to install the regulators correctly!** These parts are not the same and are not interchangeable.

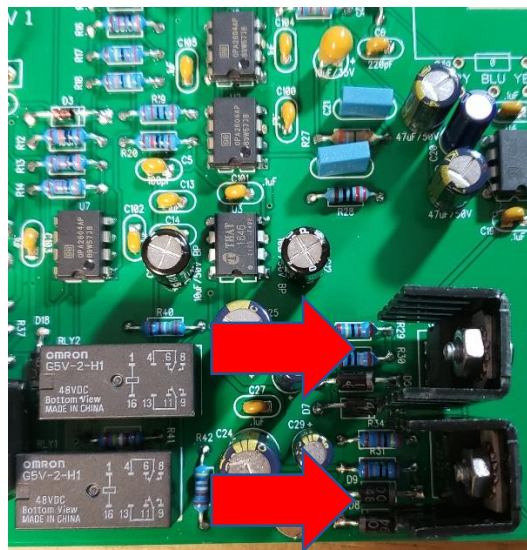

19. Check your work carefully up to this point. Don't install the other ICs yet.

Initial Power-Up and Testing.

20. Again, carefully check your work for solder bridges and open or poor joints. Make sure you've got the right resistors in the right locations. Make absolutely sure you've got all the polarized parts soldered in the right way around! Double check to make sure you haven't inadvertently swapped the voltage regulators. Fix any problems before continuing.
21. Just to make sure you haven't created any blatant shorts, measure the resistance between pins 1 and 2 of J2. Do the same for pins 3 and 2. If you measure a steady resistance of less than 100 ohms, don't apply power. Carefully check your work until you *find that short*.
22. Connect the PS04 power supply to the board using a WH01 wiring harness. **Attach the connectors so the locking ramps engage.** Don't connect the harness backwards! Set your DMM to measure DC voltages of 18V or greater and apply power. Connect the negative meter probe to J2, pin 2 or any connection labeled **PGND**. Connect the positive meter probe to the **+18V** pin 8 shown below. You should measure very close to +18V.

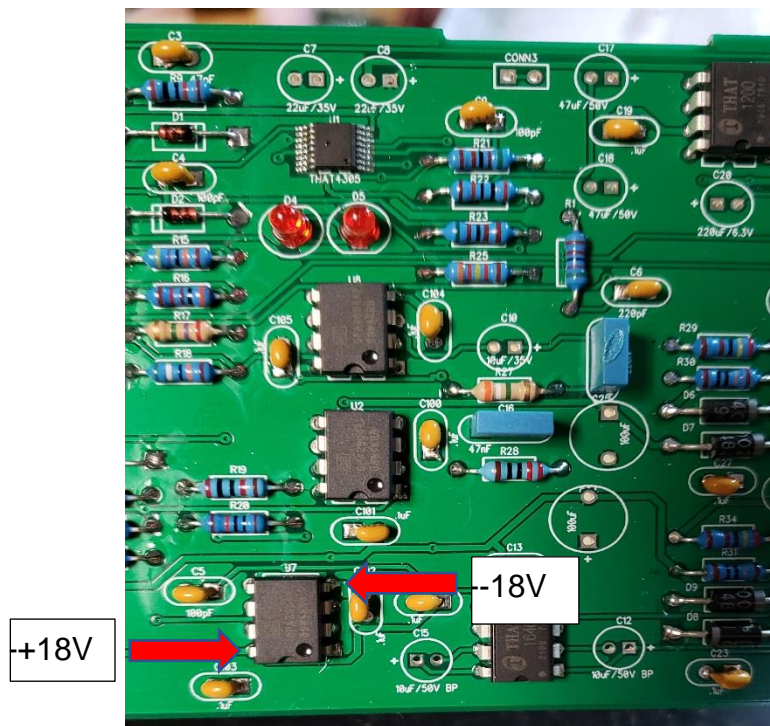

23. With the negative probe still at **PGND**, measure the voltage the **-18V** pin 4 shown above. You should measure very close to -18V.

24. Set your DMM to measure DC voltages of 50V or greater. Center toggle switch SW1. With the negative probe of your DMM connected to **PGND**, you should measure about +47V at the anodes of D17 and D18.
25. Flip SW1 to the right and measure the voltage at the anode of D17. You should see 0V.
26. Flip SW1 to the left and measure the voltage at the anode of D18. You should see 0V.
27. If the voltages measured in the previous steps are off by more than 1V, you have problems. Don't proceed until you've found them! Possible things to check are incorrectly installed diodes, especially D6 through D9, D14 through D18, backwards caps at C22, C24, C25, C29, and C31, or shorts around U5 and U6.
28. When you're certain that the voltage regulators are working, disconnect the power and install U2-U4 and U7-U8. **Be sure to handle the ICs in a static safe manner! Pay close attention to the IC markings! Align the notch on the IC with the notch on the silkscreen outline!** If you'd like the option of easily swapping or replacing the ICs, now is the time to add sockets. **Sockets are optional and are not included in the kit.**
29. If you have a few empty spaces in your chassis, you may find the next steps easier with the module installed and the front panel attached. It can also be done outside of the chassis completely.
30. Center SW1, the top toggle switch, and throw SW201, the bottom toggle switch, to the right.
31. Connect the power and apply a 1 kHz signal to the input of the B16. Adjust the signal generator output level to -10dBu. Connect the B16 output to a level meter.

32. Attach all four knobs by turning them fully **clockwise** and tightening the set screws. The output level should be in the neighborhood of +15dBu.

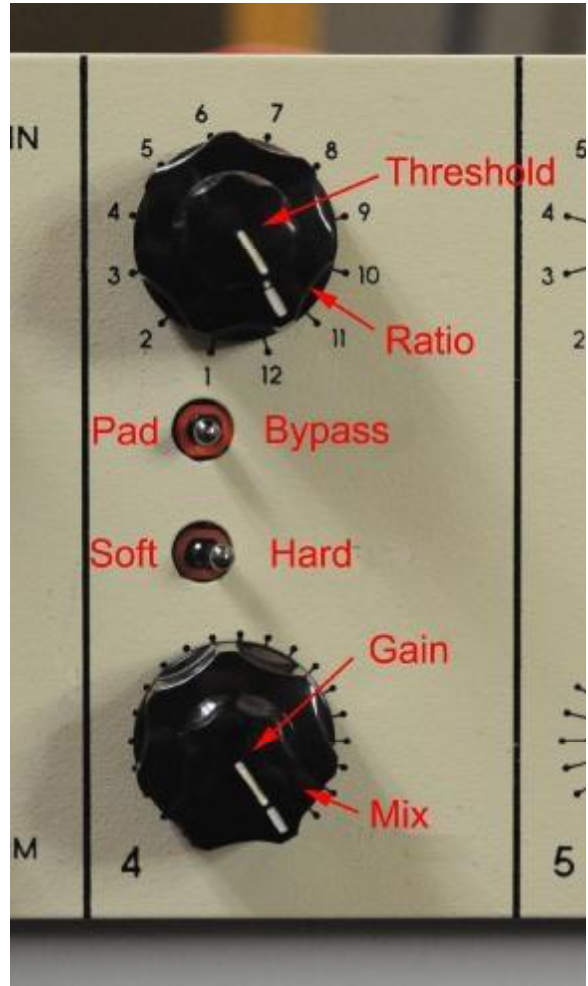

33. Center the **Makeup Gain** (bottom, inner) control.



34. Throw SW1 to the right (bypass) and observe the change in level on your meter. Adjust the gain trim pot R8 so that the output level does not change between the center and right switch positions on SW1.

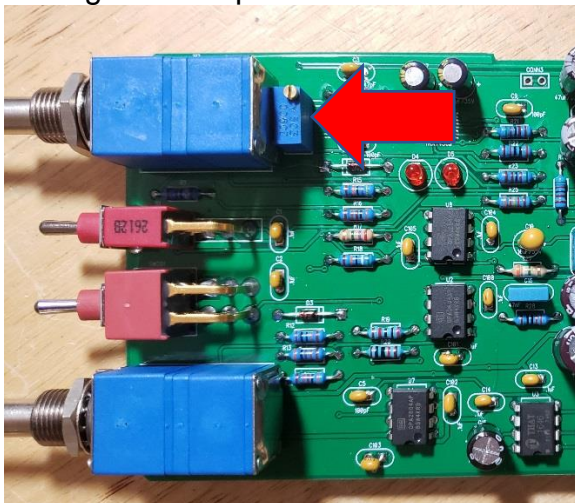

35. Congratulations! You've got a working B16 compressor.

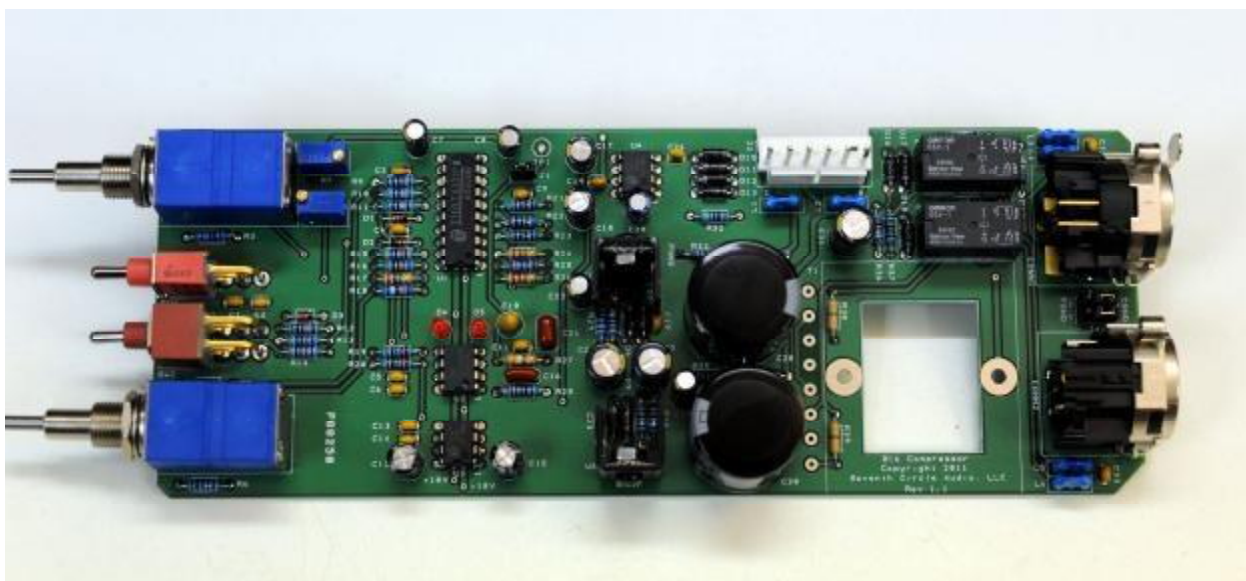

Options

1. The B16 can be ordered with an optional output transformer. If you're installing a transformer, remove (or do not install) the 0R jumpers at R38 and R39. Be sure to install spacers between the board and the transformer.
2. B16s can be linked in stereo pairs by connecting the CONN3 pad (either pad, they are shorted together) on adjacent modules. Simply solder a jumper directly between the modules. You can break the stereo link by removing the jumper at CONN3 on either board. Jumpers must be installed at CONN3 on both linked modules to complete the link circuit.

In Use

1. **Compression Ratio** – Adjustable from 1:1 (no compression) to infinite (hard limiting.) The ratio increases as the knob is turned clockwise, so maximum compression occurs with the control fully clockwise.
2. **Threshold** – Controls level where compression starts. Signals below the threshold level are not affected. The threshold level increases as the knob is turned clockwise, so maximum compression occurs with the control fully counter-clockwise.
3. **Makeup Gain** – Adjusts gain applied to the signal independent of compression. Gain range is +/-24dB.
4. **Mix** – Allows a mix of direct and compressed signal. Maximum counter-clockwise is fully “dry”, maximum clockwise is fully “wet”.
5. **SW1** – Left, 6 dB pad, Centered, normal operation, Right, hard bypass
6. **SW201** – Left, soft knee, Right, hard knee



Installation into 500 series case

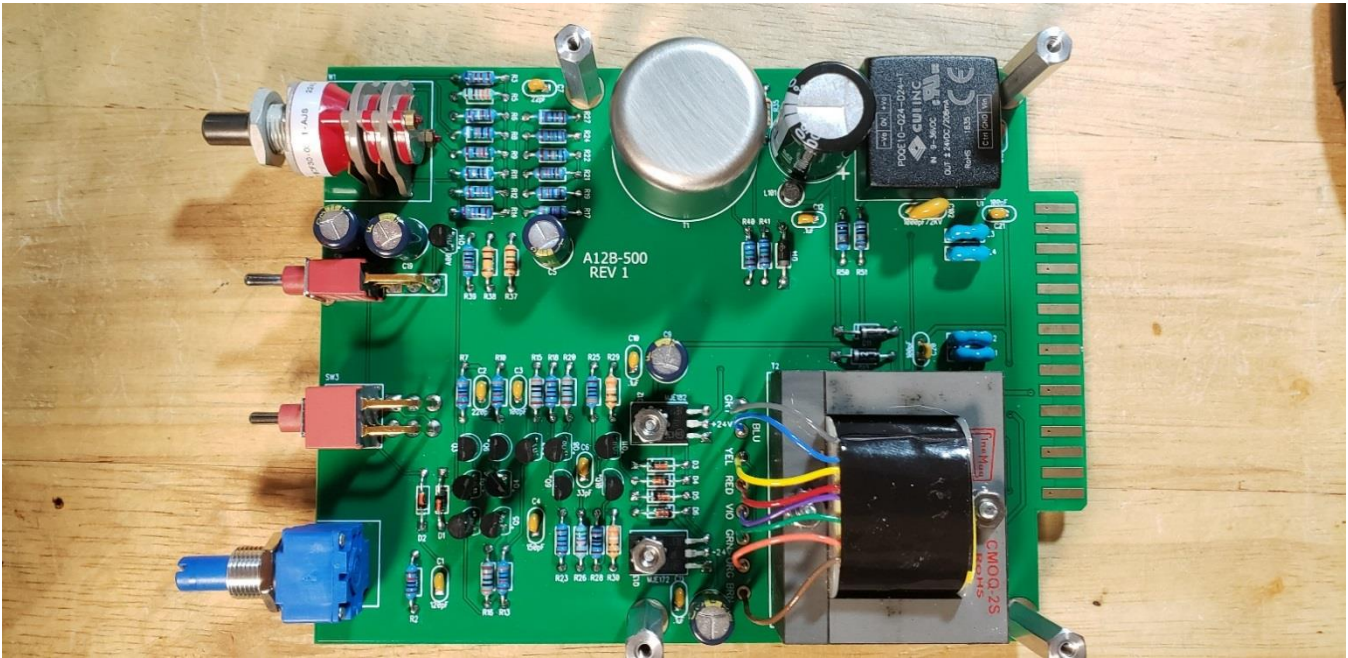

1. Make sure all 4 standoffs/spacers are installed. Short M-F spacer on the bottom, long on top of the PCB. On the dual pots, bend the small metal tab out and away from the face of the tray.
2. With nuts and washers from rotary switch and gain trim removed, fit the switches through the holes on the bottom tray. You can throw away the washers, but keep the nuts for the faceplate! The toggle switches may need to be pressed to the side to fit. If one is too far off, use the solder iron to reflow and straighten!

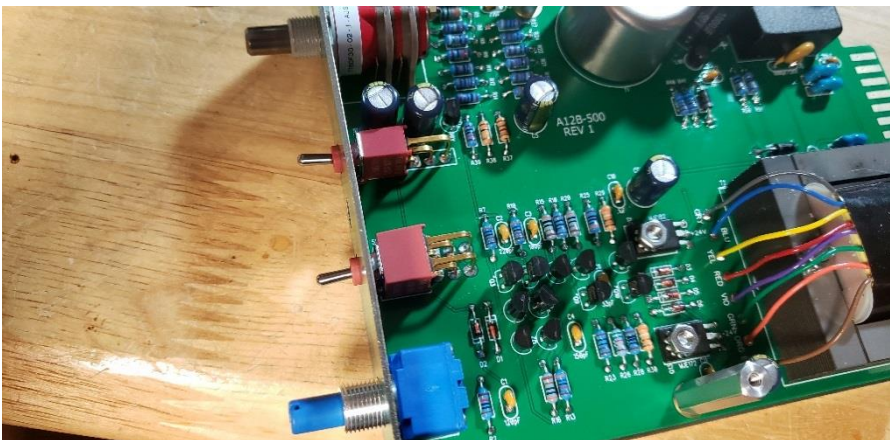

3. Use 4 small flat head screws to secure PCB to bottom tray.



4. Install cover using 4 small flathead screws. (Cover may or may not have hole for transformer.)

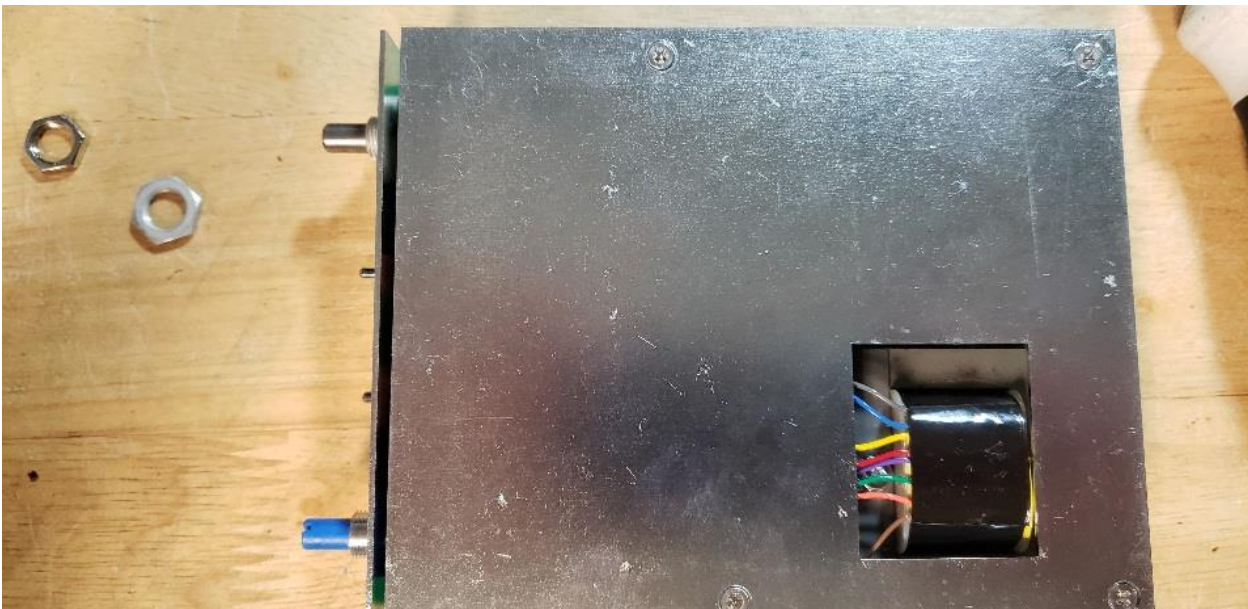

5. Attach faceplate using the nuts, but NOT the washers! Add knobs to the front.



Congratulations! You have completed your build!